2. Roadmap towards Restoration from the Accident (Step 2 Completed)

(as of January 27, 2012)



Summary of the Step 2 Completion of “Roadmap towards Restoration from the Accident”

- Confirmed the reactors were brought to a condition equivalent to “cold shutdown” and stabilized (in case an accident occurs, we will be able to keep the radiation dose at the site boundaries at a sufficiently low level)
- The targets other than reactors had been achieved as follows, thus the completion of the Step 2 “Release of radioactive materials is under control and radiation doses are being significantly held down” was confirmed.

Progress status of "Roadmap towards Restoration from the Accident at Fukushima Daiichi Nuclear Power Station" on December 16

[Issue (1) Reactors]: Achieved “condition equivalent to cold shutdown”

RPV bottom temperatures and internal PCV temperatures are, in general, below 100°C. Release of radioactive materials from PCV is under control and public radiation exposure by additional release is being significantly held down. The mid-term safety of the circulating water cooling system is secured.

[Issue (2) Spent fuel pools]: Achieved “more stable cooling”

[Issue (3) Accumulated water]: “Total volume of accumulated water has been reduced”

[Issue (4) Groundwater]: The start of water shielding wall construction marked the achievement of Step 2

[Issue (5) Atmosphere/Soil]: Unit 1 reactor building cover completion marked the achievement of Step 2.

[Issue (6) Measurement, Reduction, Announcement]: Full fledged decontamination work has begun according to the cabinet decision of the basic policy based on the Special Act

[Issue (7) Tsunami, Reinforcement, etc.]: Seismic safety assessment of the reactor buildings has completed in all Units. A support structure at the bottom of the Unit 4 Spent Fuel Pool has been installed.

[Issue (8) Living/working environment]: Living/working environment has been improved via the construction of temporary dormitories and on-site rest stations.

Improved working environment that was harsh in the immediate aftermath of the accident via providing healthier meals, installing bathing & laundry facilities, and setting up temporary dormitories & on-site rest stations, thus maintaining worker motivation.

[Issue (9) Radiation control/Medical care]: Health care has been improved via restoring appropriate radiation controls and organizing a medical care system, etc.

Countermeasures for medical care have been implemented: countermeasures against heatstroke and influenza, radiation control system reinforcements, thorough exposure control, consideration for long-term healthcare.

[Issue (10) Staff training/personnel allocation]: Continue staff training and continue to consider a strategy to effectively procure required staff

Promote staff training, especially for high-demand staff engaged in radiation work, in conjunction with the government and TEPCO.

[Action plan for mid-and-long term issues]: Confirmed that the mid-term safety of the circulating cooling system has been secure.

The facility operation plan in light of the mid-term safety was developed, followed by the government review. Hereafter, the government and TEPCO’s mid-and-long-term countermeasure conference will be established, which will develop mid-and-long term roadmap and promote necessary on-site work and R&D towards decommissioning.

Current Status of “Roadmap towards Restoration from the Accident at Fukushima Daiichi Nuclear Power Station, TEPCO” (Step 2 completion)

December 16, 2011
 Nuclear Emergency Response Headquarters
 Government-TEPCO Integrated Response Office

Red colored shading: already reported to the government, Green colored shading: achieved target

Issues	As of Apr. 17 (first announcement)		Step 1 (around 3 months)		Step 2 (through the end of this year)		Mid-term issues (around 3 years)	
					current status (as of Dec. 16)			
I. Cooling	(1) Reactor	Fresh water injection	Cooling by minimum injection rate (injection cooling)	Circulating water cooling (start)	Stable cooling	Circulating water cooling (continued)	Cold shutdown condition	Maintain and Continue cold shutdown condition
			Consideration and preparation of reuse of accumulated water					Nitrogen gas injection (continued)
	(2) Spent Fuel Pool	Fresh water injection	Reliability improvement in injection operation / remote-control operation *ahead of schedule	Stable cooling	Remote-controlled injection operation	More stable cooling	Start of removal work of fuels	Protection against corrosion cracking of structural materials* *partially ahead of schedule
			Circulation cooling system (installation of heat exchanger) *partially ahead of schedule					Consideration / installation of heat exchanging function
II. Mitigation	(3) Accumulated Water	Transferring water with high radiation level	Installation of storage / processing facilities	Secure storage place	Expansion / consideration of full-fledged processing facilities	Reduction of total amount of accumulated water	Installation of full-fledged water processing facilities	
			Storing water with low radiation level				Decontamination / desalination processing (reuse), etc	Continuous processing of accumulated water
	(4) Ground water		Mitigation of contamination in groundwater	Mitigate ocean contamination	Storage / management of sludge waste etc.	Mitigation of contamination in the ocean	Storage / management of sludge waste etc.	
			Consideration of method of impermeable wall against groundwater		Mitigation of contamination in the ocean		Research on processing of sludge waste etc.	
(5) Atmosphere / Soil		Dispersion of inhibitor	Mitigate scattering	(Restoration of sub-drainage pumps with expansion of storage / processing facilities)	Mitigate ocean contamination (continued)	Mitigation of contamination in groundwater		
		Removal / management of debris		Design / implementation of impermeable wall against groundwater		Establishment of impermeable wall against groundwater		
		Installation of reactor building cover (Unit 1)		Dispersion of inhibitor (continued)		Dispersion of inhibitor		
		Removal of debris (top of Unit 3&4 R/B)		Removal / management of debris (continued)		Removal / management of debris		
		Consideration of reactor building container		Installation of reactor building cover (Unit 1)		Removal of debris / installation of reactor building cover (Unit 3&4)		
		Installation of PCV gas control system		Removal of debris (top of Unit 3&4 R/B)		Start of installation work of reactor building container		
				Consideration of reactor building container		Installation of PCV gas control system		

Current Status of “Roadmap towards Restoration from the Accident at Fukushima Daiichi Nuclear Power Station, TEPCO” (Step 2 Completion)

December 16, 2011
 Nuclear Emergency Response Headquarters
 Government-TEPCO Integrated Response Office

: already reported to the government. Green colored shading: achieved target

Issues		As of Apr. 17 (first announcement)	Step 1 (around 3 months)	Step 2 (through the end of this year) current status (as of Dec.16)	Mid-term issues (around 3 years)	
III. Monitoring/ Decontamination	(9) Measurement, Reduction and Disclosure	Expansion, enhancement and disclosure of radiation dose monitoring in and out of the power station			Decontamination	Continuous environmental monitoring
		Consideration/start of full-fledged decontamination				Continuous decontamination
IV. Countermeasures against aftershocks, etc	(7) Tsunami, Reinforcement, etc	Enhancement of countermeasures against aftershocks and tsunami, preparation for various countermeasures for radiation shielding			Mitigate disasters	Continue various countermeasures for radiation shielding
		(Unit 4 spent fuel pool) Installation of supporting structure		Consideration of reinforcement work of each Unit		Reinforcement work of each Unit
V. Environment improvement	(8) Living/working environment	Improvement of workers' living / working environment			Enhancement of environment improvement	Improvement of workers' living / working environment
	(9) Radiation control / Medical care	Improvement of radiation control / medical system			Enhancement of healthcare	Improvement of radiation control / medical system
	(10) Staff Training / personnel allocation	Systematic implementation of staff training / personnel allocation			Exhaustive radiation dose control	Systematic implementation of staff training / personnel allocation
Action plan for mid-and-long-term issues				Concept of mid-term security		
				Establishing plant operation plan based on mid-term security		Response based on the plant operation plan
				Formulating a mid-and-long-term roadmap		

Achieved “condition equivalent to cold shutdown”

- “Circulating water cooling” started in Step 1 (Jun. 27), which reuse the contaminated water accumulated in the buildings etcetera (accumulated water) after being processed for water injection into the reactors.
- Injection cooling and release-control / mitigation of radioactive materials from the PCVs
 - ✓ Stabilized below 100 degrees via circulating water cooling
 - ✓ Internal PCV temperatures stabilized below 100 degrees even though it is difficult to grasp where the damaged fuels are located in RPV and/or PCV.
 - ✓ If damaged fuels had leaked into the PCV, steam generation would be suppressed due to sufficient cooling, thus the release of radioactive materials from the PCV has kept in control.

RPV bottom temperatures

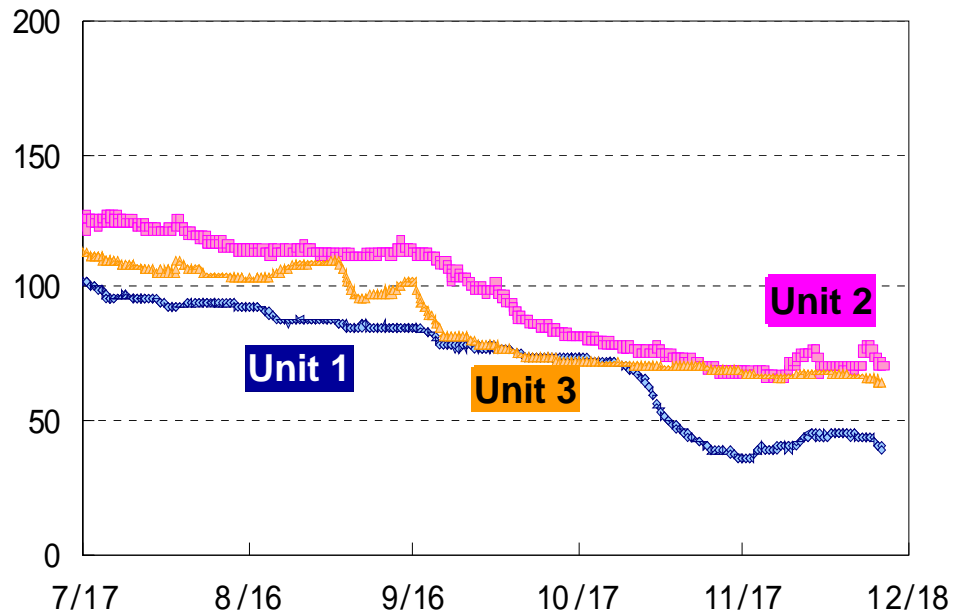

Internal PCV temperatures

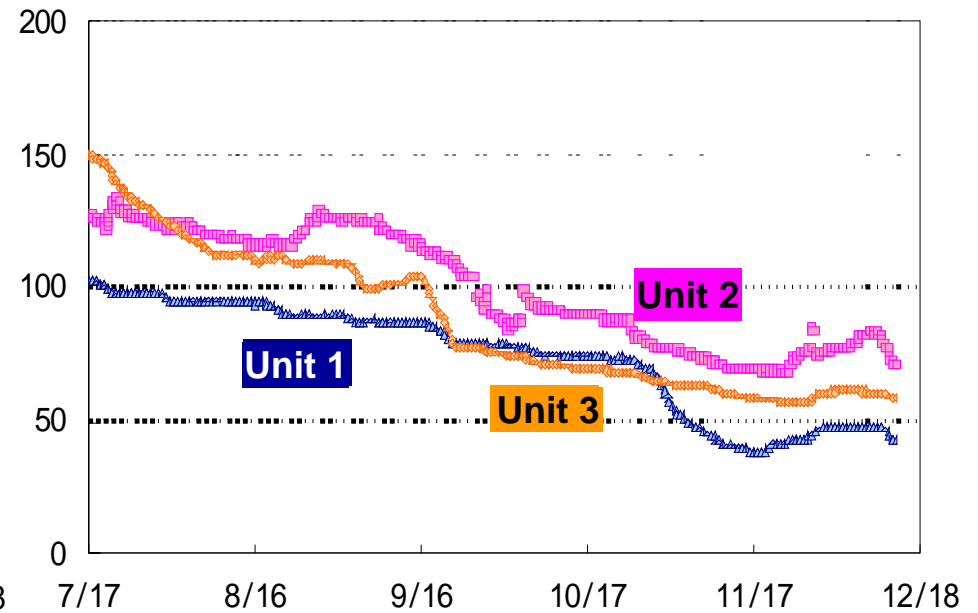

Unit 1 Cooling Condition (Steam Generation)

Comparison of the penetration point on the 1st floor



Steam release from the penetration on 1st floor
(photo as at Jun. 3)



Situation of the penetration on 1st floor
with no steam release
(photo as at Oct. 13)

Steam release from the penetration point on the 1st floor was observed on Jun. 3, however no longer confirmed on Oct. 13.



Steam generation has been stopped or so little as to be condensed before leaking into the building, if any. (Therefore inside the PCV should have been cooled.)

Unit 2 Cooling Condition (Steam Generation)



Steam release from right above the reactor on 5th floor (photo as of Sep. 17)



Situation of 5th floor of reactor building with no steam release (photo as of Oct. 20)

- Steam release was observed on Sep. 17, however no longer confirmed on Oct. 20.
- In addition, the paints of the overhead crane were being stripped off on Oct. 20, which shows that the air is dry (the adhesion of the paints had been weakened via humidity and then the paints were stripped when the air was dried.)



Steam generation has been stopped or so little as to be condensed before leaking into the building, if any.
(Therefore inside the PCV should have been cooled.)

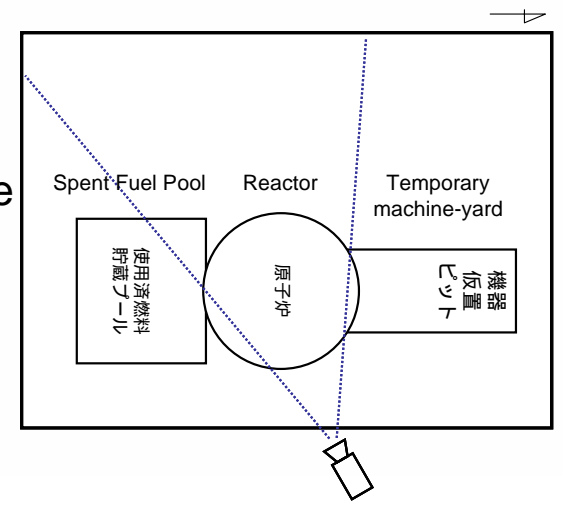

Unit 3 Cooling Condition (Steam Generation)

Thermographic monitoring from the sky

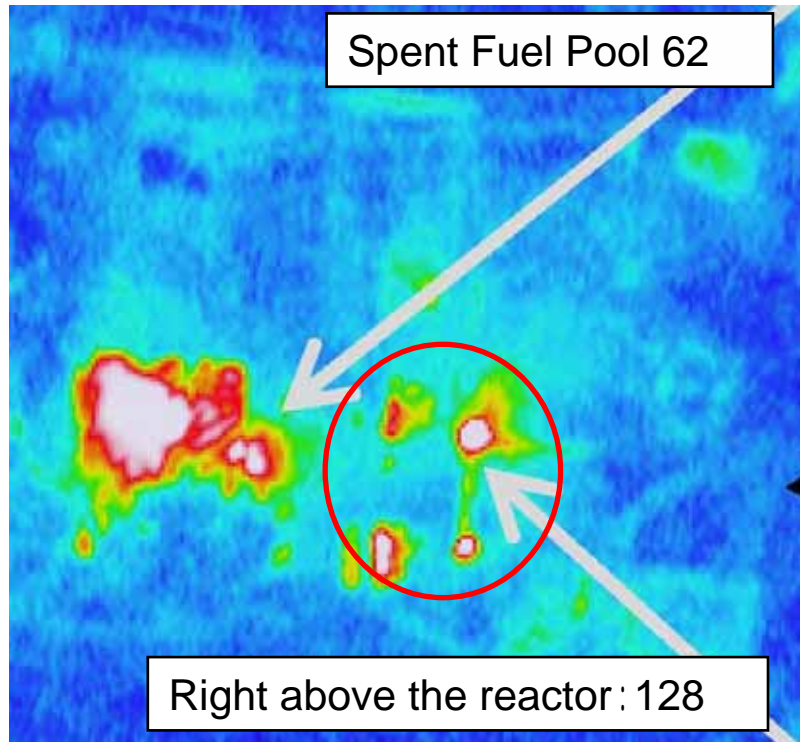

As of Mar. 20 (by Self-Defense Forces)



As of Oct. 14

The area of high temperatures as of Oct. 14 is narrowed compared to that as of Mar. 20.



Steam generation has been decreased (the inside of PCV has been cooled.)

- Utilizing the airborne radioactivity concentration at the upper parts of the reactor buildings etc., the total current release rate (Cs) from Units 1 to 3 is estimated to be approximately 0.06 billion Bq/hour. This is approximately 13 millionth of the release rate right after the accident.
- The exposure dose at the site boundaries due to aforementioned is assessed at 0.1 mSv/year at the maximum (excluding the effect of radioactive materials already released until now.) The legal dose limit is 1 mSv/year.

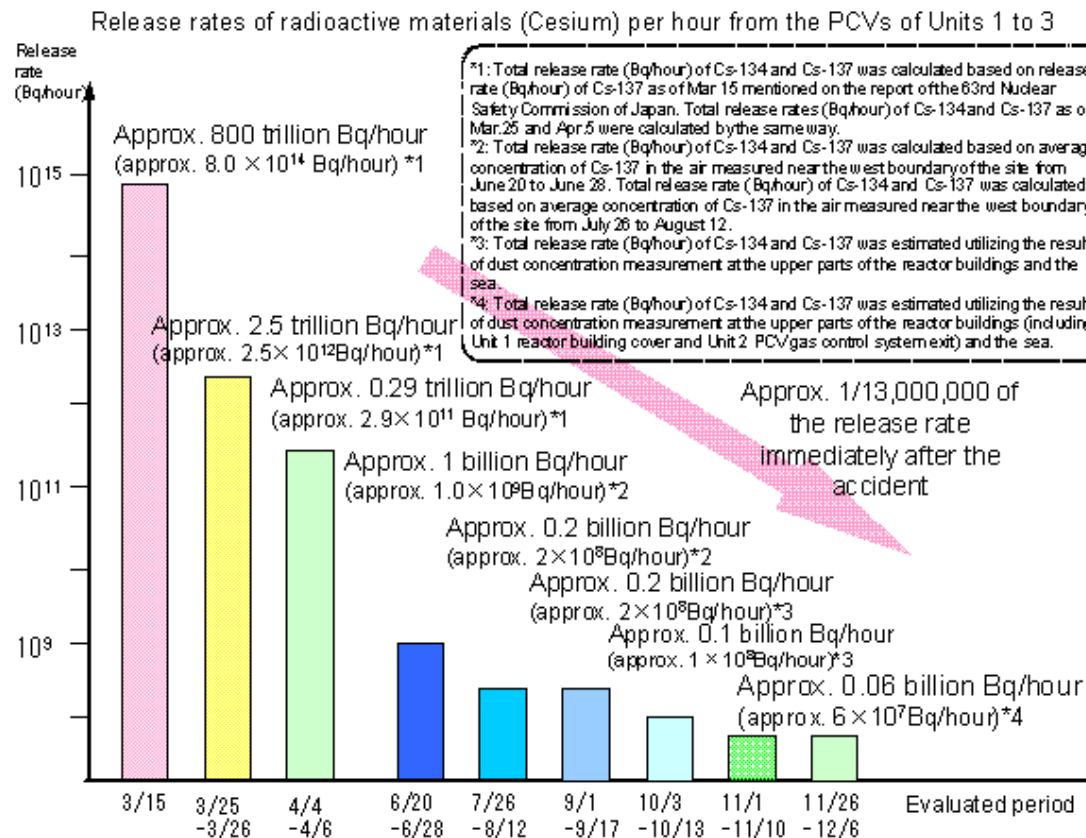

Reactors

Having secured mid-term safety of circulating water cooling system

- The operation management plan of TEPCO Fukushima-Daiichi Units 1 to 4 based on the midterm security concept was assessed appropriate by NISA.
- RPV/PCV water injection system has comprised water injection pumps, injection lines and tanks which have redundancy, diversity and independency.
 - ✓ Water source has comprised of filtered water tank, processed water buffer tank and pure water tank.
 - ✓ Water injection pumps has comprised of regular pumps on a hill, emergency pumps on a hill, pumps besides pure water tank and fire trucks for emergency backup.
 - ✓ Water injection lines has comprised of a line from processed water buffer tank through regular and emergency injection pumps on a hill and a line from pure water tank via a pump besides pure water tank.

Example: Outline of Water Injection Line at Unit 3

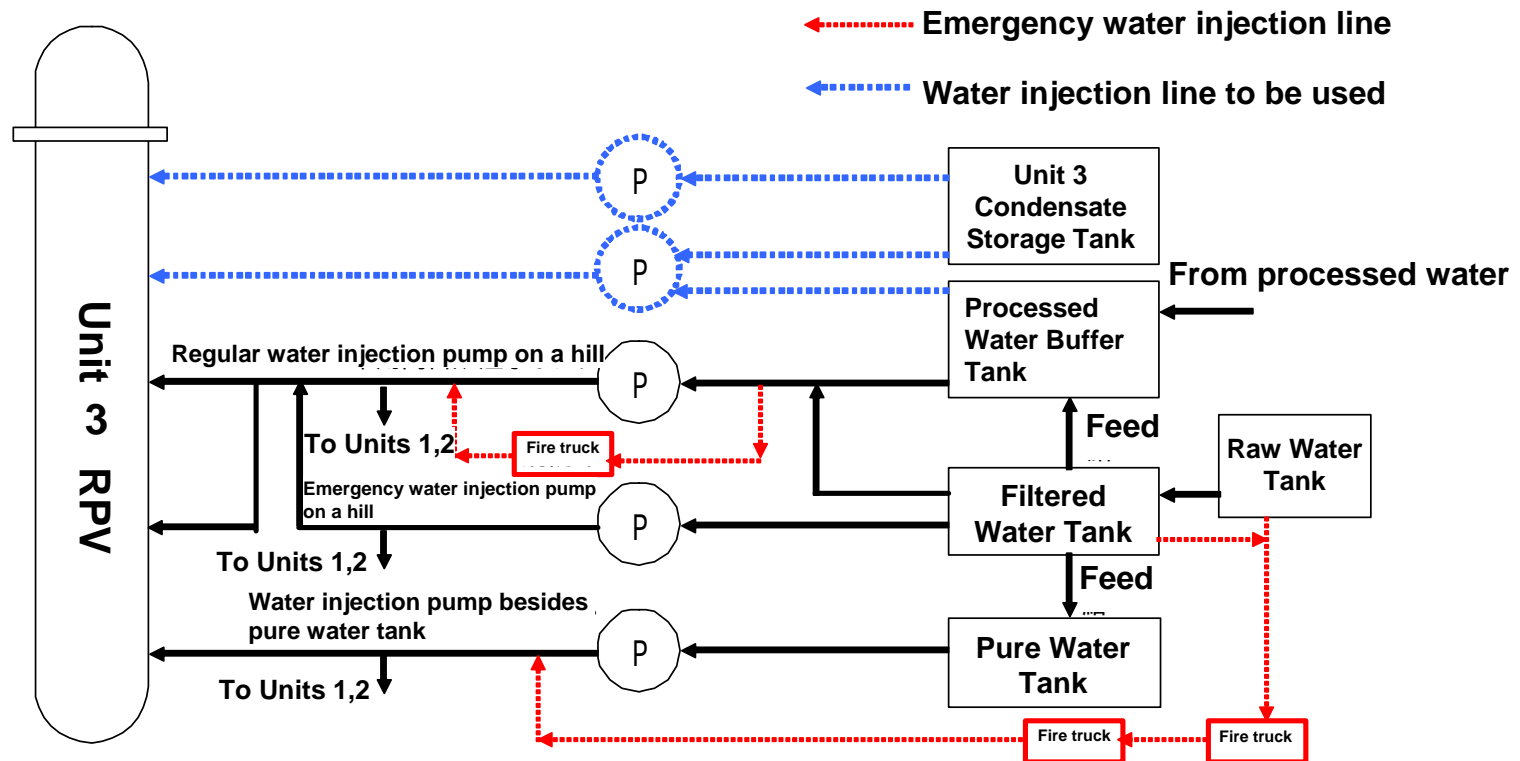

- Having installed heat exchangers and maintained pool water level, we achieved “More stable cooling” (Step 2 target) at Units 2 and 3 at the end of Step 1.
- Circulating cooling systems for Units 1 and 4 had also been installed, thus the Step 2 target was achieved in all Units on Aug. 10.
- The desalination facility for Unit 4 has begun operation on Aug. 20. The desalination facilities for Units 2 and 3 are planned to be installed in turn.



Heat exchanger has been installed (Example of Unit 1)

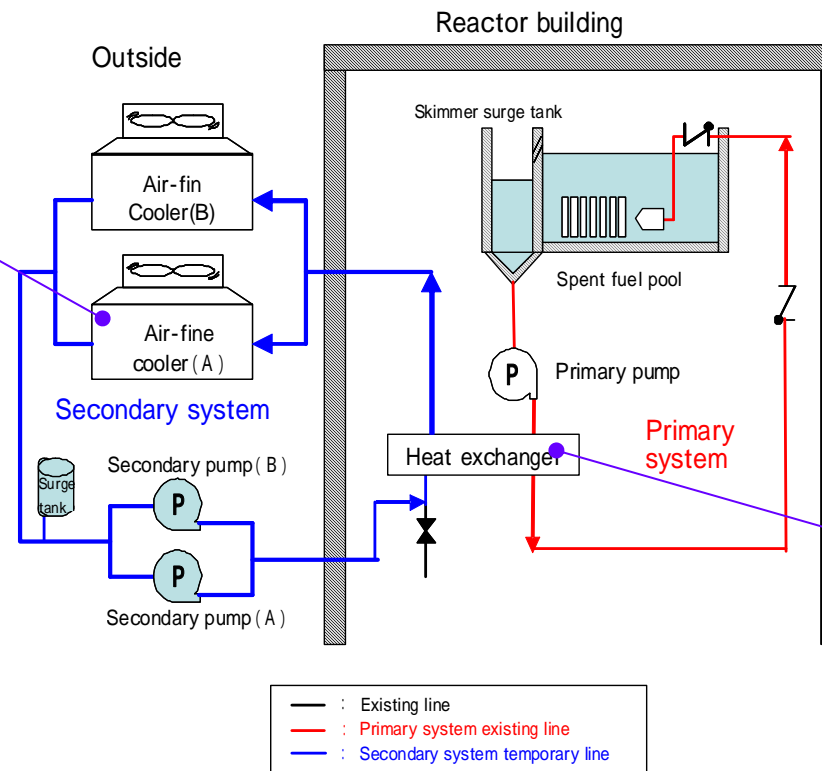

- Confirmed “the reduction of total volume of accumulated water” due to processing the accumulated water in the buildings via stable operation of processing facilities. Following countermeasures were implemented to achieve this end.
 - ✓ Reinforcement of high-level contaminated water processing facilities, stable operation and expansion of water reuse after desalination.
 - ✓ Begun consideration of full fledged high-level contaminated water processing facilities.
 - ✓ Storage and management of waste sludge generated from high-level water processing facilities.
 - ✓ Construction of steel pipe sheet pile at the site harbor started in order to mitigate the contamination into the ocean.

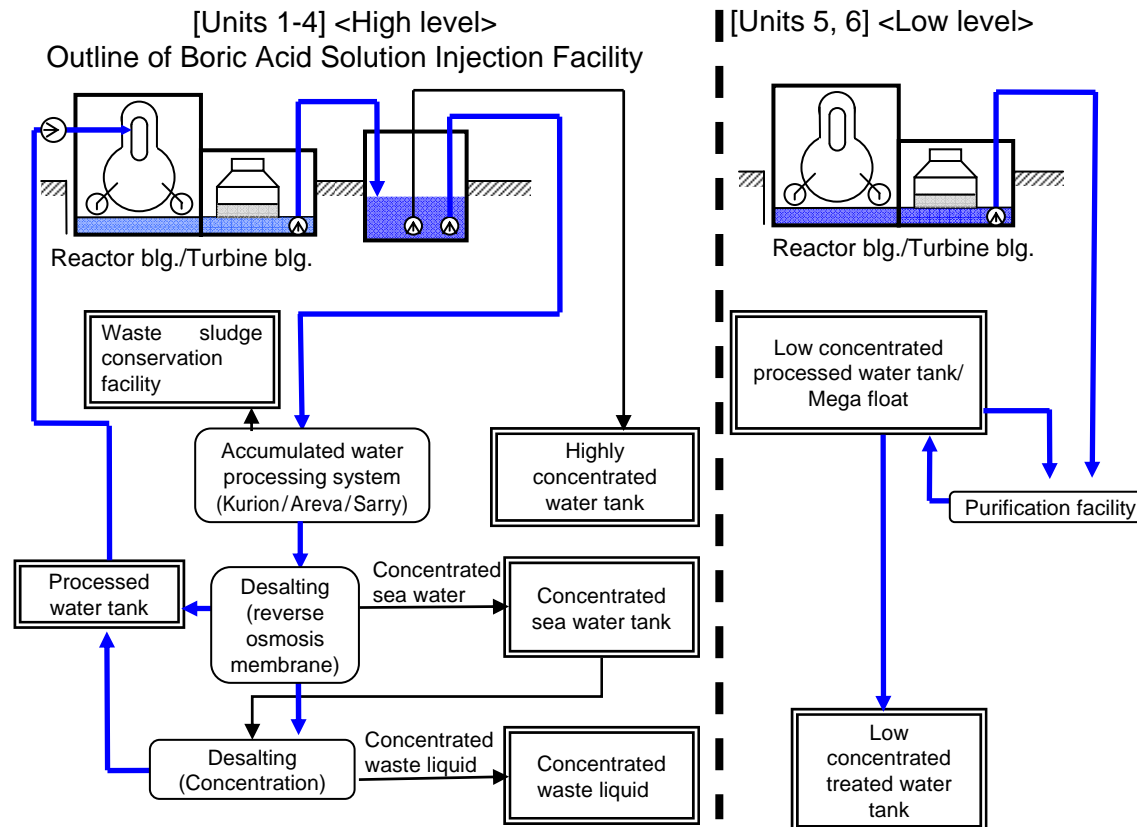

- After full-scale use of SARRY from Aug. 18, the accumulated water level reached the target level of O.P 3,000, where it is able to withstand heavy rains as well as long-term processing facility outages.
- At this point, we are continuing and enhancing Circulating water cooling.

Control of Accumulated water in Turbine Building

<Status of the accumulated water processing>

- **Accumulated water processing performance**
approx. 189,610 tons in total (as of Dec.13)
- **Cs decontamination factor***
10⁶ in the apparatus of Kurion – Areva (as of Aug. 9)
6 X 10³ in the apparatus of Kurion (as of Nov. 29)
5 X 10⁵ in SARRY (as of Nov. 29)
- **Chlorine concentration**
Decreased from 1,700 ppm to approx. 3 ppm (by the reverse osmosis equipment , as Nov. 29 result)
Decreased from 9,000 ppm to less than 1 ppm (by the evaporative concentration apparatus as of Nov. 29 result)
Reinforcement of desalination processing facility by the evaporation concentration apparatus was completed (as of Oct. 9)

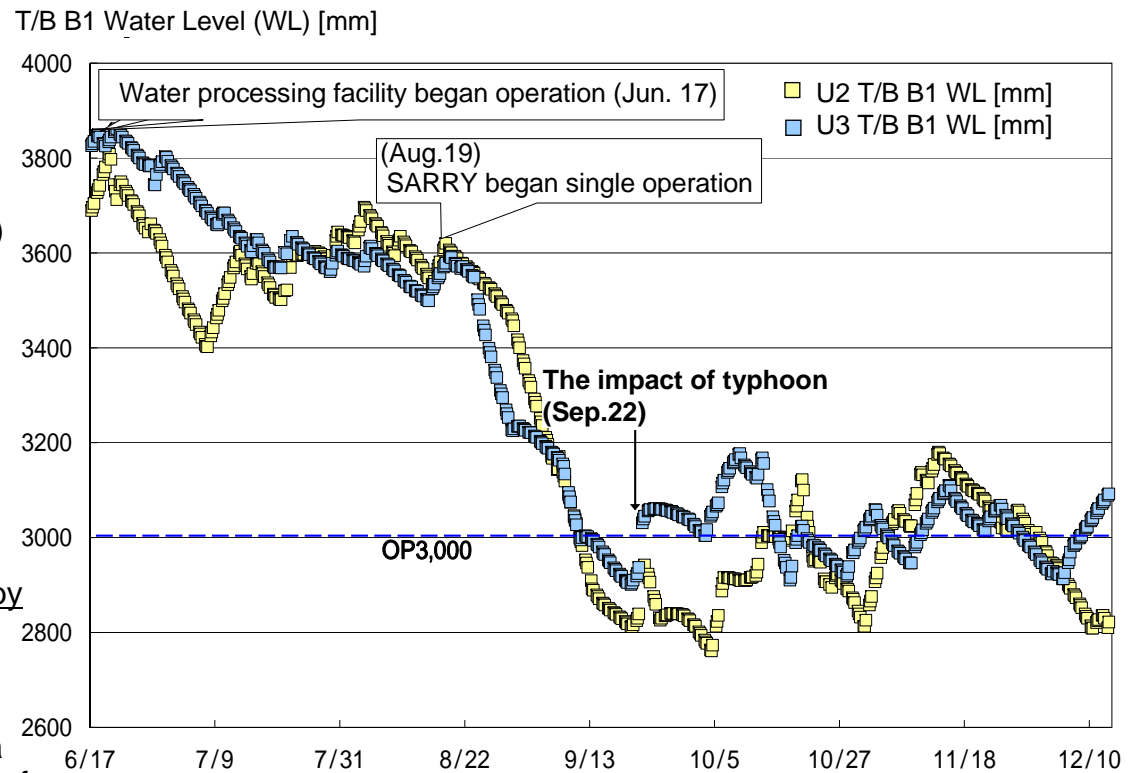

*Decontamination factor = cesium concentration of a sample before processing / cesium concentration of a sample after processing

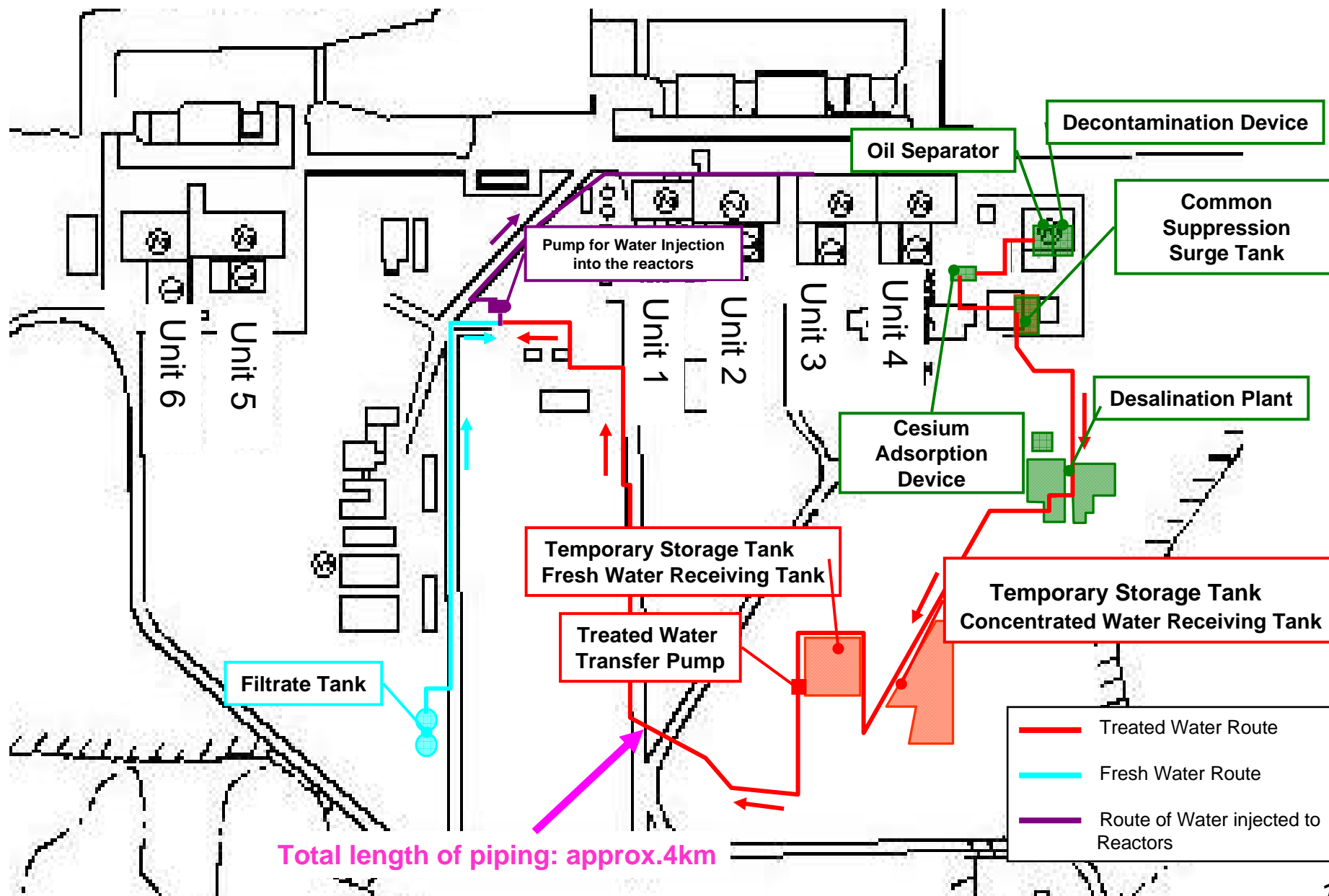

Total length of piping: approx.4km

- By controlling accumulated water flows into underground water, we implement/start preventative measures to mitigate underground water contamination as well as to halt the spread of contamination into the ocean.
 - ✓ Mitigate the leaking of accumulated water in the building by ensuring that the level of accumulated water is lower than the sub drain water level (confirm via a radioactive materials density analysis of the sub drain).
 - ✓ Start the placement of the water shielding walls in front of the existing seawall of Units 1-4 (this will prevent the spread of contaminated underground water from flowing into the ocean)

Image of water shielding wall

Overview



Cross-section

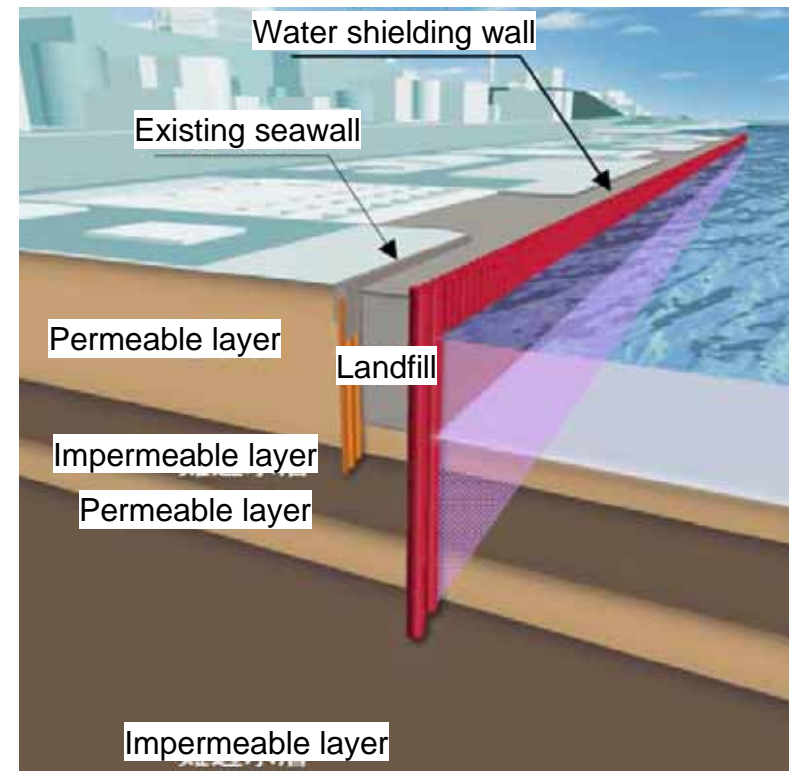

- Spraying dust inhibitor agents to mitigate spreading of powder dust containing radioactive materials.
- Completed Unit 1 reactor building cover installation (Oct. 28).
- Radiation dose at the site is being held down due to rubble removal.
 - ✓ The removed rubble and waste resulting from restoration work such as cut down trees due to site clearing were transported after we classified them by type and radiation emitting amount at storage area.
 - ✓ The rubble were placed in containers and stored indoors in accordance with the radiation emitting amount.
- Completed PCV gas control system.
 - ✓ Started operation of PCV gas control system in Unit 1 (Dec. 15) and Unit 2 (Oct. 28).
 - ✓ Started installation work in Units 3 (Sep. 30).



Unit 1 reactor building cover installation



Containers storing rubble



Spraying dust inhibitor agents to the buildings and site ground



Silt fence installation



Removal of rubble

- Monitoring was conducted by the central government, prefecture, municipalities and TEPCO.
- Full-fledged decontamination was considered and commenced.

[Government's implementation]

- ✓ Determined the "Basic policy towards implementing decontamination" and the "Basic stance towards the urgent implementation of decontamination" which sets forth the target and stance for two years onwards (Aug. 26).
- ✓ Promulgated the "Act on Special Measures concerning the Handling of Environmental Pollution by Radioactive Materials Released due to the Accident at the Nuclear Power Stations in connection with Tohoku-Chihou-Taiheiyo-Oki Earthquake on March 11, 2011" (Aug. 30).

[Activities that TEPCO is participating in]

- ✓ Based on the results of the wide area monitoring and detailed monitoring and TEPCO's knowledge (radiation control and construction supervising, etc.), in order to facilitate the Government's demonstration of the decontamination model project in the restricted area, TEPCO will cooperate with the Japan Atomic Energy Agency (JAEA), a contractor of this project.

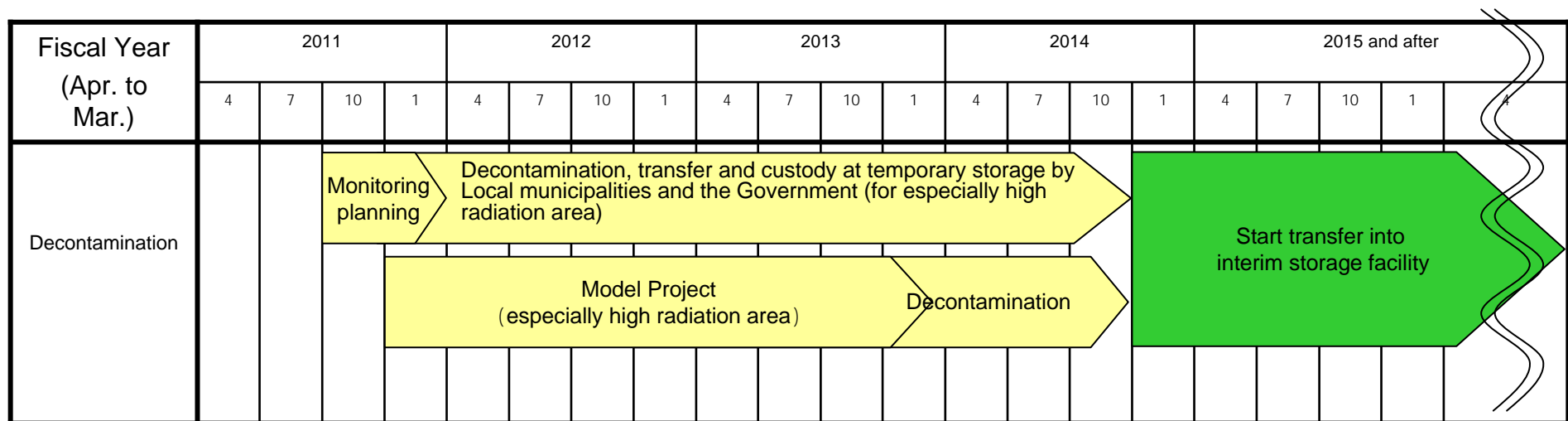

*Extract from "The basic concept of the interim storage facility required in dealing with environmental contamination due to radioactive materials resulting from the accident at Fukushima Daiichi Nuclear Power Plant, TEPCO" (Ministry of the Environment, Oct.29. 2011).

Tsunami & Reinforcement, etc.

Achievement of “Mitigate disaster impact”

- Via the seismic assessment of all Units' reactor buildings, seismic safety minus additional reinforcements has been confirmed.
- Support structure has been installed at the bottom of Unit 4 Spent Fuel Pool.
 - ✓ Support structures have been installed at the bottom of SFP to broaden the margin of safety, even though the soundness of facilities was confirmed.
- A temporary tide barrier was installed as a countermeasure against tsunamis caused by earthquakes. (May 18 ~ Jun. 30)
- Several kinds of countermeasures for radiation shielding were implemented.
 - ✓ Countermeasures were implemented to mitigate radioactive material emissions and shield radiation in the event of a prolonged suspension of water injection to the reactor or the spent fuel pool.
 - ✓ Installed facilities that will put slurry (a mixture of water and solid material such as sands) through the upper part of the reactors and spent fuel pools in order to mitigate radioactive material emissions as well as shield radiation.



Before steel post installation (May 31)



Injecting grout (Jul. 30)

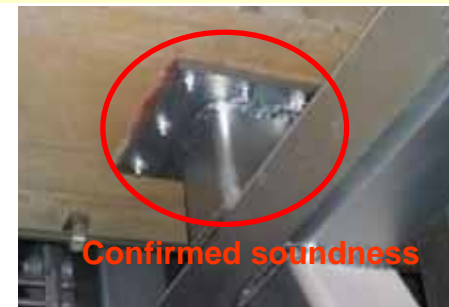

Support structure for piping



Installing steel post (Jun. 20)



Placing concrete (Jul. 21)



Installation of temporary tide barrier

- Setting up of rest stations for workers in each area as well as water coolers, toilets and air showers.
- Improving the living environment of Fukushima Daini gymnasium, where the workers are residing, and completed construction of temporary dormitory able to accommodate 1,600 persons.
- Having improved meals such as providing lunchboxes for lunch and supper from May.



Inside the rest place in former
Emergency Response Room



Bunk beds in gymnasium
at Fukushima Daini



Toilet in rest room



Drinking water at rest place in former
Emergency Response Room



Shower room in gymnasium
at Fukushima Daini



Air shower in rest place

- Improving health care
 - ✓ Conducting additional health checkups every month for those workers whose exposure dose exceeds 100 mSV and who engage in emergency work for over a month. Implementation rate of special health checkups in October was 86.5 % (as of Nov. 16).
 - ✓ Routine check ups of recent health conditions and the tracking of the medical history of new site workers has begun
- Increase the number of whole body counters (WBC) and conduct periodical measurements of the internal exposure dose of workers
 - ✓ The number of WBC was increased as planned (12 units have already been installed as of Oct. 3)
 - ✓ From September, once-a-month internal exposure measurements were started.
- Exposure control has being enhanced.
 - ✓ At the beginning of Step 1 some workers were exposed to dosage amounts exceeding the limit. Hence exposure controls were tightened and countermeasures were developed to prevent recurrences.
 - ✓ Automated record-keeping of personal radiation dosage data was started via installing access control system utilizing a bar-code and introducing worker photo identification.
- Medical system improvement will be continued
 - ✓ Medical room and care system was established, where multiple doctors, nurses and radiation specialists are on duty at any given time in a 24 hour period 7 days a week.
 - ✓ By improving the medical and decontamination facilities, we are able to ensure speedy patient transportation and direct transportation to hospitals of emergency patients who have not been contaminated



WBC installation



Medical room inside the Main Anti-earthquake building



influenza Vaccination

- Promoting staff training in conjunction with the Government and TEPCO
 - ✓ Conduct training for high-demand staff engaged in radiation related work
 - ✓ TEPCO has been conducting “radiation survey staff training” targeting employees and TEPCO group company employees and has already trained approx. 4,400 personnel
 - ✓ The government conducted “Radiation Survey Staff Training” and “Radiation Protection Staff Training”
 - ✓ In accordance with affiliated companies’ needs, launched a new framework to find workers nationwide through the Japan Atomic Industrial Forum (JAIF).
- Striving hard to secure adequate number of staff
 - ✓ Since this October, TEPCO has reshuffled 70 employees (as of Dec. 9) who were exposed to high levels of radiation.
 - ✓ From the perspective of being able to procure staff continuously, TEPCO implemented a questionnaire survey to improve the work environment. Based on the results, TEPCO implemented improvements such as the reduction of the full-face mask area, speedy radiation monitoring by utilizing the gate monitor, and expansion of the parking area at J-village, etc.
 - ✓ Developing measures to reduce exposure dose in the Main Anti-Earthquake Building.



Radiation Survey Staff Training



Introduction of Remote Controlling Machine such as Robots

- Implementing restoration work in consideration of how to utilize remote controlling machines including robots to reduce radiation exposures to workers.
- At the area where high dose is expected, robots carry out visual observation or surveillance of radiation dose or work like cleaning .

<Robots already adopted>

Name	Quince	Warrior	Packbot
Appearance			
Operation	Surveys indoors	Works indoors or outdoors	Surveys indoors or outdoors



Going up stairs in Reactor Building of Unit 3 operation screen (July 26)



Cleaning in Reactor Building of Unit 3 (July 1)



Surveying high dose area in Turbine Building of Unit 1 (August 2)

Overview of Major Countermeasures in the Power Station, Final Edition

Underlined: deleted countermeasures. : already reported to the government

